

SILENT LAB

MICROOFFICE

**UNIQ
PRIME
SPARK
CUBIQ
QUADRIO
REALM
ELITE**

ICONIC DESIGN
REVOLUTIONARY VENTILATION SYSTEM
VIRTUALLY SOUNDPROOF
SOPHISTICATED DETAILS
TOP-TIER MATERIALS

MICROOFFICE

ABOUT US	7
CONCEPT	9
ACOUSTICS / DESIGN / TECHNOLOGY / MATERIALS	11
MICROOFFICE UNIQ	15
MICROOFFICE PRIME	21
MICROOFFICE SPARK	25
MICROOFFICE CUBIQ	31
MICROOFFICE QUADRIO	41
MICROOFFICE QUADRIO I	42
MICROOFFICE QUADRIO II	44
MICROOFFICE QUADRIO III	46
MICROOFFICE QUADRIO IV	48
MICROOFFICE REALM	51
MICROOFFICE ELITE	55
DESIGNERS	61
OPTIONAL EQUIPMENT	63
AV TECHNOLOGY	64
FURNITURE	66
CURTAINS	68
CLARITY PROTECT	70
TOUCHONE	72
MATERIAL LINES	77
FABRIC SWATCHES	78
MICROOFFICE EQUIPMENT	85





We like peace and quiet when we work. That's why we started SilentLab, where we create quiet and send it wherever it's needed the most. Our original office acoustical solutions carve out oases of calm and privacy even in the noisiest interior environments.

Open offices are more popular than ever, but along with greater interaction comes overwhelming noise. Thanks to our team of acoustics experts, we enable companies to provide employees with the distraction-free workspaces they need to perform and collaborate at optimal levels. Our unique mobile soundproof offices, acoustical wall panels, ceiling hangings and other sound-reduction accessories are all made at our in-house production facilities in the Czech Republic.

Our holistic approach to sustainable sound empowers us to create complete acoustic solutions. We can also work with you to devise highly customized solutions precisely tailored to your needs. Visual appeal is as important to us as top-tier performance, which is why all our products combine unique designs with maximum functionality.



MICROOFFICE is an oasis to minimalism in the shape of an independent workspace. It is the bridge between the two halves of its environment, creating a private and peaceful inner world in the center of the chaos around it. These two realms are linked through vision, energy, light and sensation.

The MICROOFFICE design approach is one of duality, an act of balance between fundamental principles – body and space, transparent and unobtrusive, unyielding yet soft, intimate yet open.

The interior space is ensconced on all sides by a solid shell. The resulting object is opaque from one point of view, a tangible barrier dividing two worlds. From another perspective, it is nearly invisible as it merges with its surroundings. The glass ceilings of the UNIQ and larger QUADRIO models bathe the occupant in soothing natural light.

We've selected the materials used to create MICRO-OFFICE with great care. As a result, the serene design reflects both the simplicity and power contained within our concept.

CONCEPT



ACOUSTICS

MICROOFFICE is an answer to the basic question of acoustic comfort. Layers of solid wood and acoustic materials, along with sound-insulating glass, a sonically sealed door and a silent ventilation system, make for maximum soundproofing between the interior and exterior spaces.

The extensive surface area provides optimal distribution of acoustic materials, leading to the creation of a quiet, pleasant interior environment. The entire structure has been calibrated to counter the specific frequencies of the human voice, making it an ideal setting for phone or conference calls.

DESIGN

Based on the above principles, the concept and features mesh in perfect harmony. On two sides, solid facades protect the user from the most persistent sources of noise. The reassuring back wall evokes a feeling of security, while the opaque front eliminates visual distractions.

The other faces are made entirely of sound-insulating glass. The solid walls protruding above the ceiling create the unmistakably iconic "U" shape of the MICROOFFICE UNIQ.

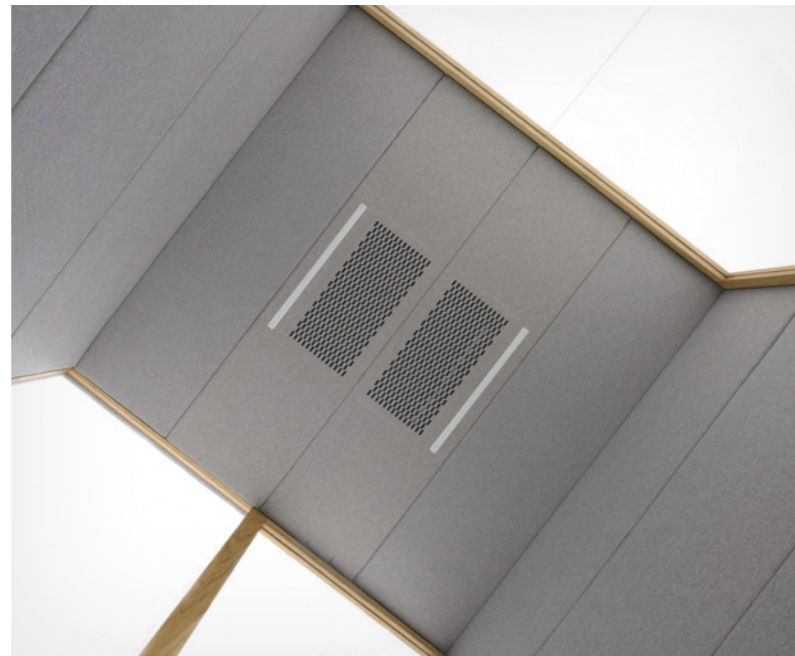
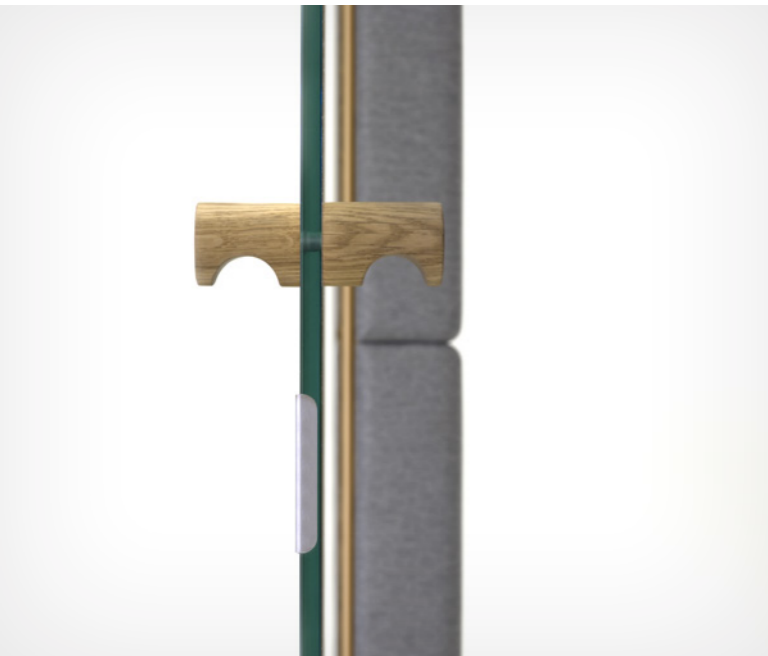

TECHNOLOGY

Central to the MICROOFFICE experience is its cutting-edge ventilation system. Exclusive to our product family, this completely new innovation promises untold levels of comfort. With ultra-efficient ventilation supplying a constant stream of fresh air, users can enjoy the distraction-free solitude of our revolutionary workspaces for hours on end.

Each MICROOFFICE unit comes fully equipped with everything needed to perform at optimal levels. Electrical sockets, USB and LAN connections and an LED light are standard across the entire product line.

MATERIAL

Our choice of materials reflects our commitment to the dual principles of MICROOFFICE. As such, we've upholstered the entire solid shell, while the transparent glass insulates against sound on both sides.

Horizontal divisions across the upholstered surfaces connote scale, while hand-crafted details around the border of each piece add subtle elegance. The entire structure is inspired by the ideal ergonomic height for a table or bar stools. Design accents and interior accessories are carved from solid oak.

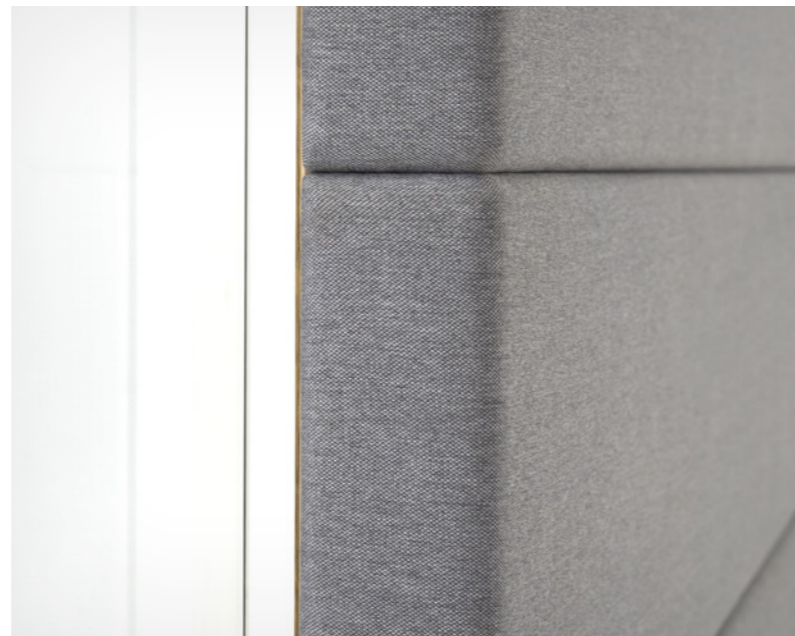





MICROOFFICE UNIQ captures an insulated bubble of peace without the burden of difficult installation or renovation. Our new iconic design features a unique ventilation system, high-end acoustic materials and even more sophisticated details than before.



reddot design award
winner 2019





MICROOFFICE UNIQ

UNIQ

TECHNICAL DETAILS

exterior dimensions	1177 x 1004 x 2285 mm / 46.3 x 39.5 x 90 in
interior dimensions	898 x 933 x 2097 mm / 35.4 x 36.7 x 81.9 in
weight	385 kg / 848 lb
glass walls	sound-insulating glass
solid walls	sound-absorbing sandwich panel with acoustic insulation
glass wall frame and door handle	solid oak/black varnish
ceiling	sound-insulating glass
flooring	carpet (anthracite grey)
ventilation	automatic/manual
lighting	LED, chromaticity temperature 2 700 K
included equipment	desk, electric socket (1x), USB connection (1x), motion sensor, design lamp, ventilation
optional equipment	barstool, coat hook (detailed equipment list available on page 85)
color options	decorative fabric (refer to swatches)

certification    *

* FSC certification on request

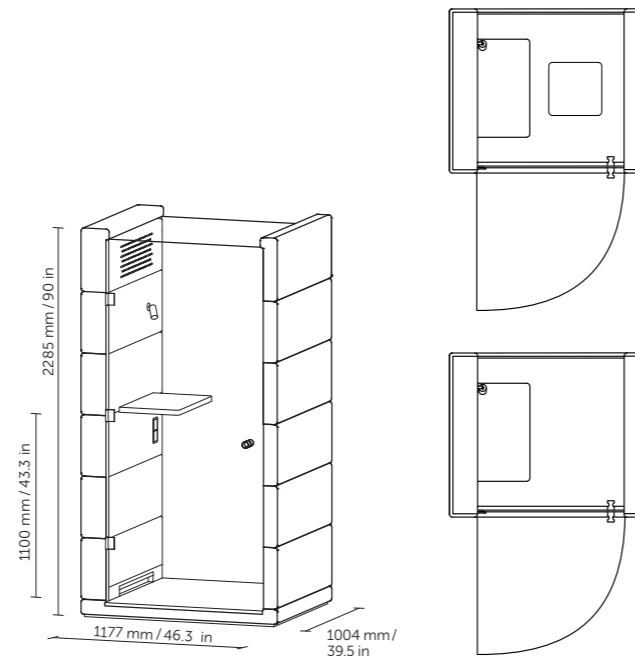





MICROOFFICE PRIME is a standalone haven of silence ready for use without any burdensome installation or renovation. It combines our iconic visual aesthetic with a unique ventilation system, high-end acoustic materials, sophisticated details and practical design.



MICROOFFICE PRIME

PRIME

TECHNICAL DETAILS

exterior dimensions	1175 × 995 × 2285 mm / 46.3 × 39.5 × 90 in
interior dimensions	900 × 915 × 2080 mm / 35.4 × 36 × 81.9 in
weight	370 kg / 815 lb
glass walls	sound-insulating glass
solid walls	sound-absorbing sandwich panel with acoustic insulation
glass wall frame and door handle	solid oak/black varnish
ceiling	sound-absorbing sandwich panel with acoustic insulation
flooring	carpet (anthracite grey)
ventilation	automatic/manual
lighting	LED, chromaticity temperature 4 200 K
included equipment	desk, electric socket (1x), motion sensor, LED lighting, ventilation
optional equipment	barstool, coat hook, USB and LAN connection (detailed equipment list available on page 85)
color options	decorative fabric (refer to swatches)
certification	  

* FSC certification on request

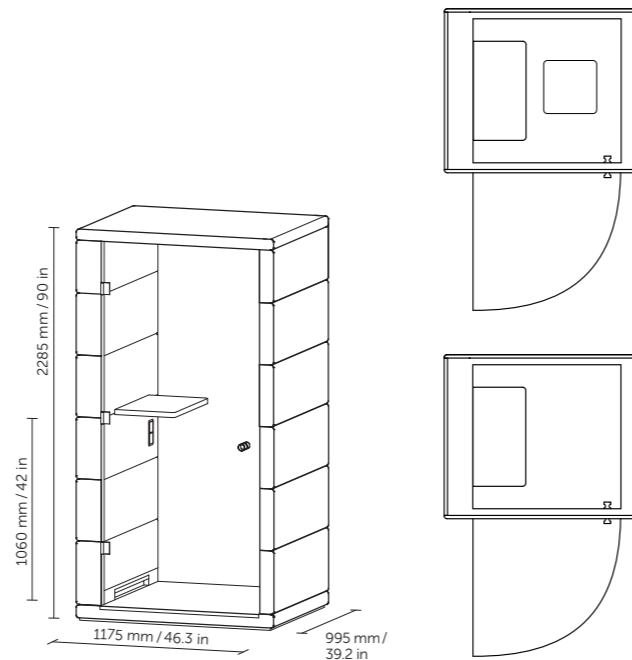



MICROOFFICE SPARK is the first acoustic office pod with increased mechanical durability while maintaining superior functional parameters. You can place it in any challenging production area conditions.

MICROOFFICE SPARK

SPARK

TECHNICAL DETAILS

exterior dimensions	1189 x 930 x 2226 mm / 46,8 x 36,6 x 87,6 in
interior dimensions	924 x 864 x 2057 mm / 36,3 x 34 x 80,9 in
weight	350 kg / 771 lb
glass walls	high performance sound-insulating glass
solid walls	sound-absorbing sandwich panel with acoustic insulation
glass wall frame and door handle	solid oak wood
ceiling	sound-absorbing sandwich panel with acoustic insulation
flooring	carpet (anthracite grey)
ventilation	automatic / manual
lighting	LED, chromaticity temperature 4200 K
included equipment	USB-C (1x), motion sensor, desk, LED lighting, ventilation
optional equipment	electric socket (1x), barstool (detailed equipment list available on page 85)
color options	refer to swatches
certification	CE

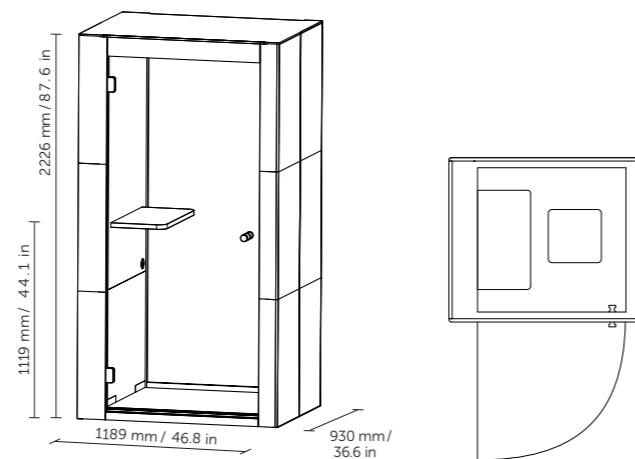



MICROOFFICE CUBIQ turns any area into a private multi-person meeting room. Enjoy unprecedented flexibility with two-person to four-person standing configurations.





reddot design award
winner 2019

MICROOFFICE CUBIQ

CUBIQ

TECHNICAL DETAILS

exterior dimensions	1777 x 1600 x 2285 mm / 70 x 63 x 90 in
interior dimensions	1501 x 1480 x 2074 mm / 59.1 x 58.3 x 81.7 in
weight	600 kg / 1 322 lb
glass walls	sound-insulating glass
solid walls	sound-absorbing sandwich panel with acoustic insulation
glass wall frame and door handle	solid oak / black varnish
ceiling	sound-absorbing sandwich panel with acoustic insulation
flooring	carpet (anthracite grey)
ventilation	automatic/manual
lighting	LED, chromaticity temperature 4 200 K
included equipment	electric socket (2x), motion sensor, LED lighting, control panel for lighting and air ventilation
optional equipment	seats, coat hooks, USB and LAN connection (detailed equipment list available on page 85)
color options	decorative fabric (refer to swatches)

certification   

* FSC certification on request

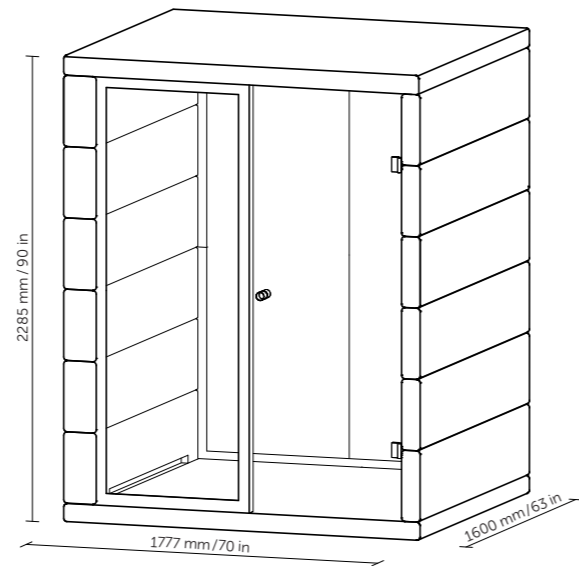
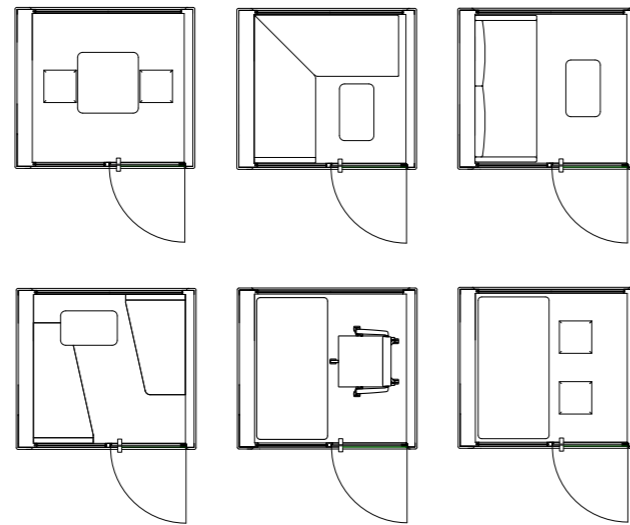

EQUIPMENT OF MICROOFFICE

ONE TO ONE

Upholstered benches, material and color of the fabric according to the swatch.
Metal black legs. Table is oiled oak top and leg made of metal with black surface finish. (The black version of the MICROOFFICE also has a black table top).

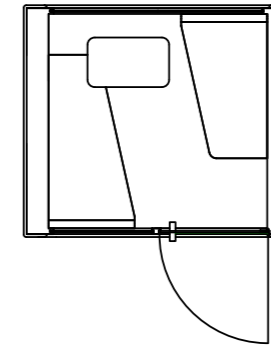
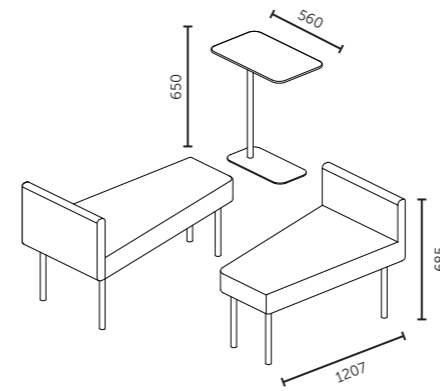

RELAX

Upholstered armchair, material and color of the fabric according to the swatch.
Metal black legs. Table is oiled oak top and leg made of metal with black surface finish. (The black version of the MICROOFFICE also has a black table top).

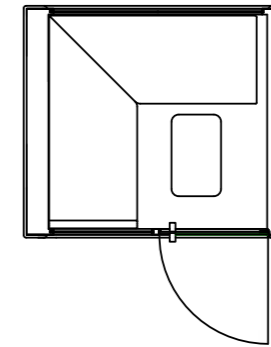
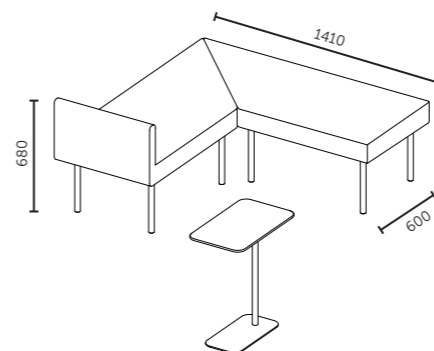

VIDEOCONFERENCE

Upholstered armchair, material and color of the fabric according to the swatch. Metal black legs. Table is oiled oak top and leg made of metal with black surface finish. The black version of the MICROOFFICE also has a black table top. Preparation for video conferencing – TV holder in the full wall.

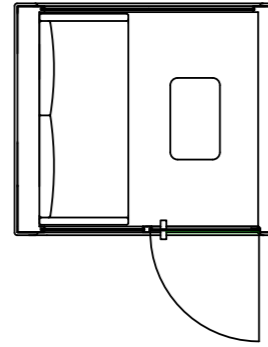
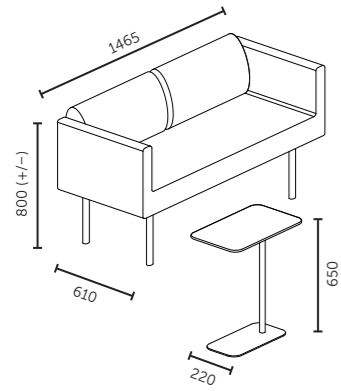

FOCUS

Height-adjustable table assembly with black metal base.

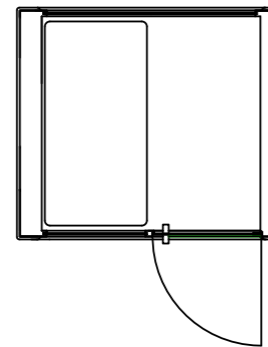
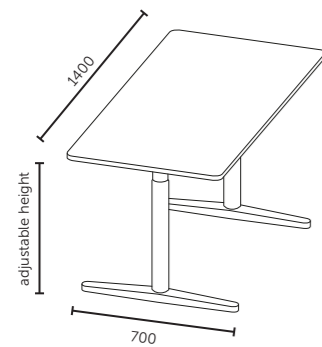

DUO

Height adjustable table and 2x bar chair TON Rioja.

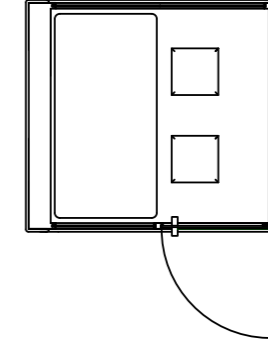
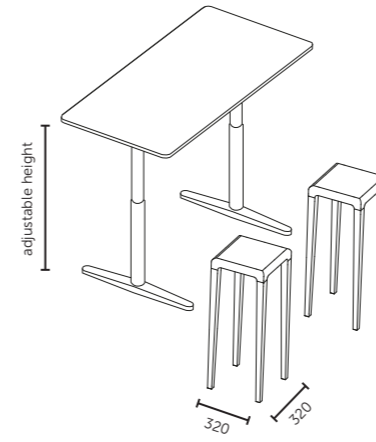

EQUIPMENT OF MICROOFFICE





MICROOFFICE QUADRIO is available in several variants. Just choose the optimal size that suits you and your colleagues.



MICROOFFICE QUADRIO

QUADRIO I

TECHNICAL DETAILS

MICROOFFICE QUADRIO I is the ideal meeting space for a quick and private conversation with a colleague. Private, personal and just the right size for two occupants.

exterior dimensions	2520 x 1317 x 2285 mm / 99.2 x 51.9 x 90 in
interior dimensions	2246 x 1196 x 2128 mm / 88.4 x 47.1 x 83.8 in
weight	625 kg / 1 377 lb
glass walls	sound-insulating glass
solid walls	sound-absorbing sandwich panel with acoustic insulation
glass wall frame and door handle	solid oak/black varnish
ceiling	sound-absorbing sandwich panel with acoustic insulation
flooring	carpet (anthracite grey)
ventilation	automatic/manual
lighting	LED, chromaticity temperature 4 200 K
included equipment	electric socket (2x), motion sensor, LED lighting, control panel for lighting and air ventilation
optional equipment	desk, seats, coat hooks, USB and LAN connection (detailed equipment list available on page 85)
color options	decorative fabric (refer to swatches)

certification   

* FSC certification on request

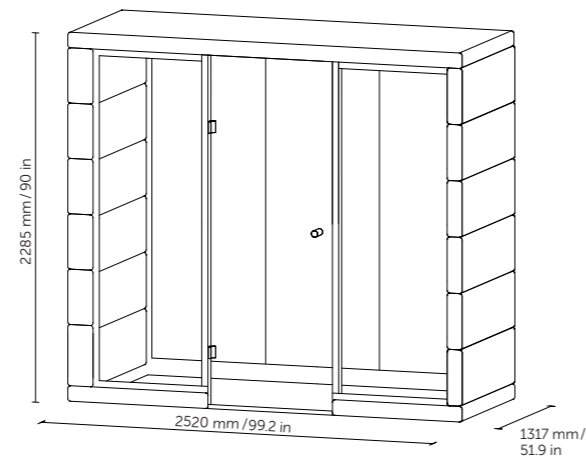
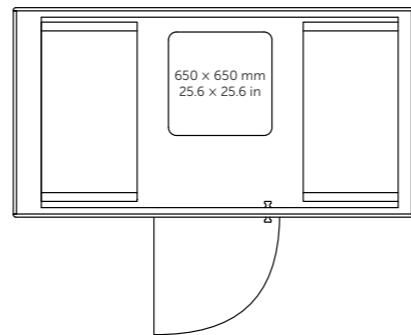
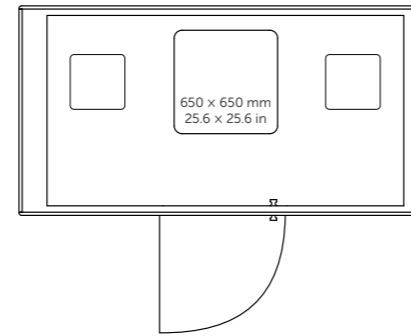

QUADRIO II

TECHNICAL DETAILS

Do you need a place to meet with several colleagues from your team? Try MICROOFFICE QUADRIO II, which offers space for up to five people.

exterior dimensions	2522 x 1944 x 2285 mm / 99.2 x 76.5 x 90 in
interior dimensions	2246 x 1824 x 2128 mm / 88.4 x 71.8 x 83.8 in
weight	750 kg / 1 653 lb
glass walls	sound-insulating glass
solid walls	sound-absorbing sandwich panel with acoustic insulation
glass wall frame and door handle	solid oak / black varnish
ceiling	sound-absorbing sandwich panel with acoustic insulation
flooring	carpet (anthracite grey)
ventilation	automatic/manual
lighting	LED, chromaticity temperature 4 200 K
included equipment	electric socket (3x), motion sensor, LED lighting, control panel for lighting and air ventilation
optional equipment	AV connection points, desk, seats, coat hooks, USB and LAN connection (detailed equipment list available on page 85)
color options	decorative fabric (refer to swatches)

certification   

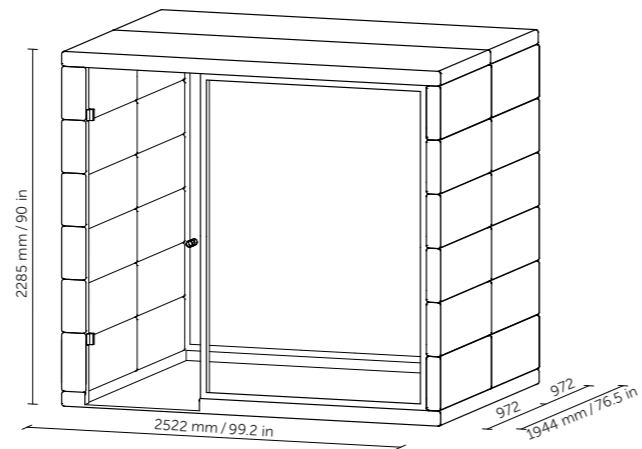
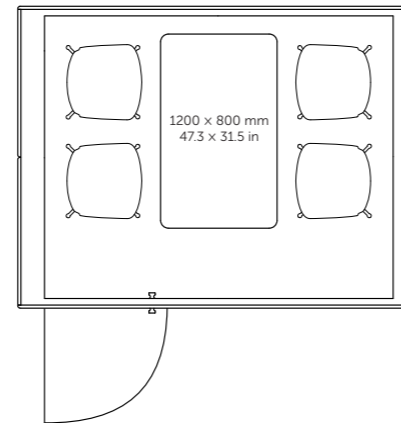

* FSC certification on request



QUADRIO III

TECHNICAL DETAILS

MICROOFFICE QUADRIO III is perfect for groups of up to seven people. Its optional glazed ceiling gives the room plenty of light, providing a comfortable setting for longer meetings.

exterior dimensions	2522 x 2856 x 2285 mm / 99.2 x 112.4 x 90 in
interior dimensions	2245 x 2736 x 2128 mm / 88.4 x 107.7 x 83.8 in
weight	950 kg / 2 094 lb
glass walls	sound-insulating glass
solid walls	sound-absorbing sandwich panel with acoustic insulation
glass wall frame and door handle	solid oak / black varnish
ceiling	sound-absorbing sandwich panel with acoustic insulation and sound-insulating glass
flooring	carpet (anthracite grey)
ventilation	automatic / manual
lighting	LED, chromaticity temperature 4 200 K
included equipment	electric socket (3x), motion sensor, LED lighting, control panel for lighting and air ventilation
optional equipment	AV connection points, desk, seats, coat hooks, USB and LAN connection (detailed equipment list available on page 85)
color options	decorative fabric (refer to swatches)
certification	  

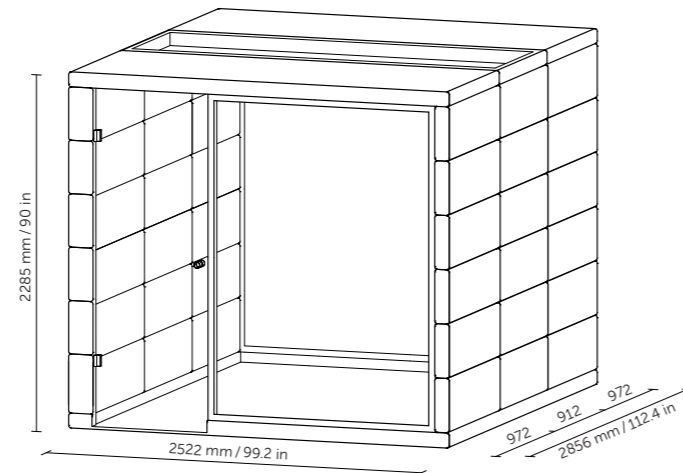
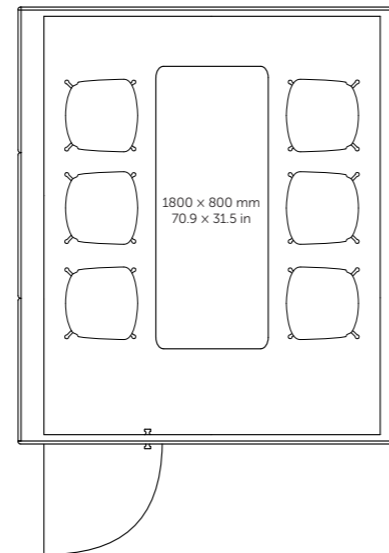

* FSC certification on request

QUADRIO IV

TECHNICAL DETAILS

Able to accommodate up to nine people, our MICROOFFICE QUADRIO IV fully replaces any meeting room without the need for any building modifications. Adding the perfect conference room to your office has never been easier.

TECHNICAL DETAILS

exterior dimensions	2522 x 3768 x 2285 mm / 99.2 x 148.4 x 90 in
interior dimensions	2245 x 3648 x 2128 mm / 88.4 x 143.6 x 83.8 in
weight	1150 kg / 2 535 lb
glass walls	sound-insulating glass
solid walls	sound-absorbing sandwich panel with acoustic insulation
glass wall frame and door handle	solid oak / black varnish
ceiling	sound-absorbing sandwich panel with acoustic insulation and sound-insulating glass
flooring	carpet (anthracite grey)
ventilation	automatic/manual
lighting	LED, chromaticity temperature 4 200 K
included equipment	electric socket (3x), motion sensor, LED lighting, control panel for lighting and air ventilation
optional equipment	AV connection points, desk, seats, coat hooks, USB and LAN connection (detailed equipment list available on page 85)
color options	decorative fabric (refer to swatches)

certification   

* FSC certification on request

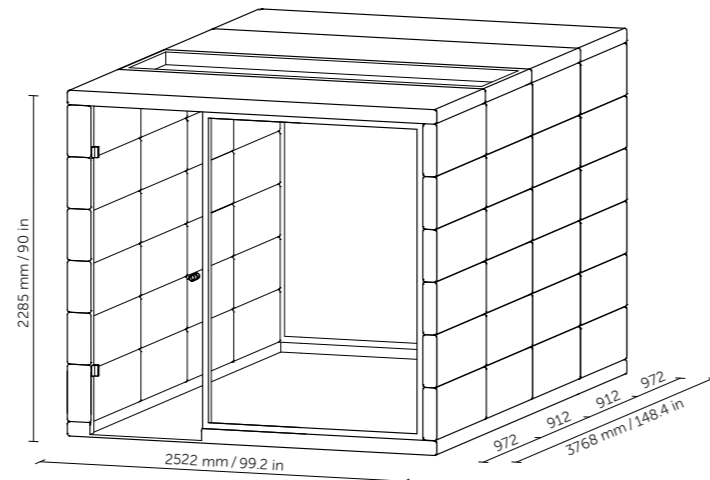
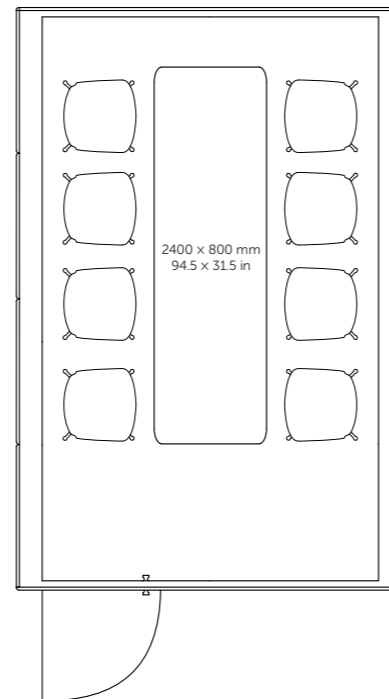



Do you work in an office but still want a quiet environment to get your work done? Finding that quiet place is easier than you think! You can find it in a meeting, while tackling a big project or during an informal gathering in our acoustic wellbeing meeting room.

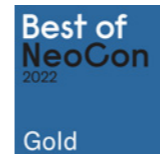

MICROOFFICE REALM

REALM

TECHNICAL DETAILS

exterior dimensions	2522 x 2856 x 2285 mm / 99.2 x 112.4 x 90 in
interior dimensions	2245 x 2736 x 2128 mm / 88.4 x 107.7 x 83.8 in
weight	950 kg / 2 094 lb
glass walls	sound-insulating glass
solid walls	sound-absorbing sandwich panel with acoustic insulation
glass wall frame and door handle	solid oak wood/black varnish
ceiling	sound-absorbing sandwich panel with acoustic insulation, sound-insulating glass
flooring	carpet (anthracite grey)
ventilation	automatic/manual
lighting	LED, chromaticity temperature 4 200 K
included equipment	electric socket (3x), motion sensor, LED lighting, control panel for lighting and air ventilation, coffee table, seats, coat hooks (3x), shelf (2x), glazed ceiling
optional equipment	AV connection points, USB and LAN connection (detailed equipment list available on page 85)
color options	decorative fabric (refer to swatches)

certification  

* FSC certification on request

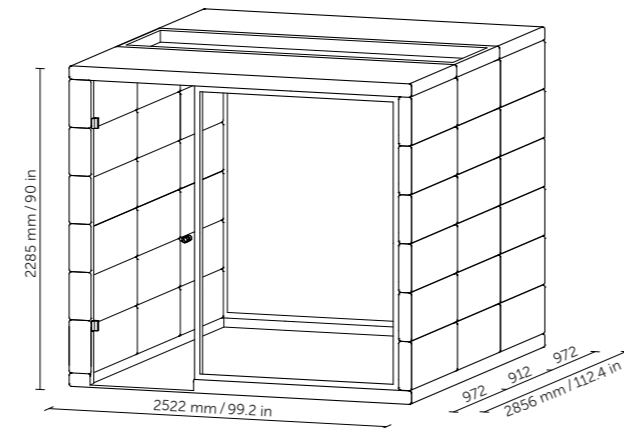
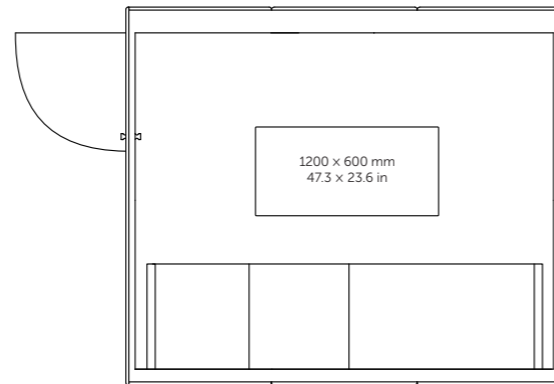
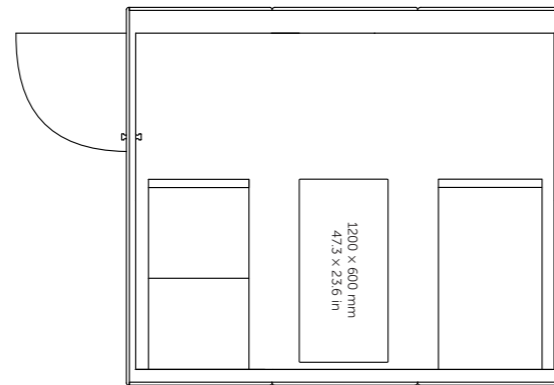

MICROOFFICE ELITE with maximum acoustic attenuation and a built-in anti-eavesdropping device. The solution will be appreciated in important meetings where protecting trade secrets is a priority. Especially suitable for law firms and discerning clients.



MICROOFFICE ELITE

ELITE

TECHNICAL DETAILS

exterior dimensions	2522 x 1944 x 2285 mm / 99.2 x 76.5 x 90 in
interior dimensions	2246 x 1824 x 2128 mm / 88.4 x 71.8 x 83.8 in
weight	750 kg / 1 653 lb
glass walls	high performance sound-insulating glass – switchable
solid walls	sound-absorbing sandwich panel with acoustic insulation
glass wall frame and door handle	solid oak wood/black varnish
ceiling	sound-absorbing sandwich panel with acoustic insulation
flooring	carpet (anthracite grey)
ventilation	automatic / manual
lighting	LED, procognitive light, chromaticity temperature 4200 K
standard equipment	electric socket (3x), desk with electric socket, procognitive lighting, motion sensor, graphic control panel for lighting and air ventilation
optional equipment	wiretapping ultrasound jammer, air-conditioning, room reservation panel, AV connection points, seats, coat hooks, USB and LAN connection (detailed equipment list available on page 85)
color options	decorative fabric (refer to swatches)
certification	CE

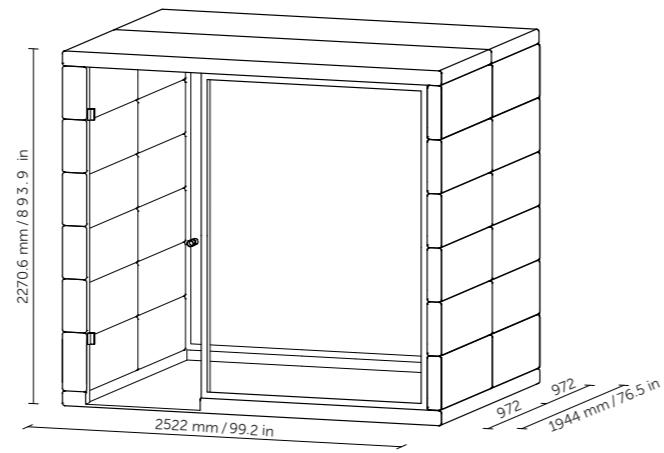
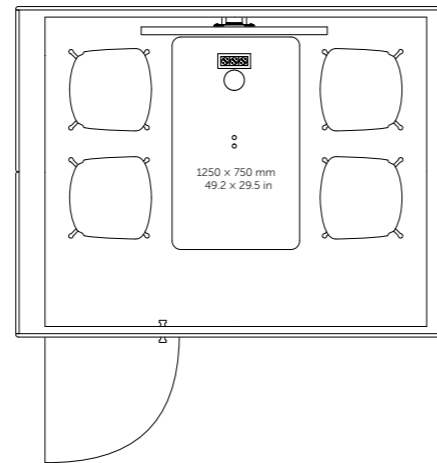





JAN KALIVODA & VOJTECH KAAS /PROGRES ARCHITECTS/

We are an architecture studio.

Since 2006 we have been working on small and large projects incorporating space, mass, light, materials and feelings. We believe that strong, functional and balanced architecture must be rooted in the specific conditions of each project.

We take pride in a job well done.

The quality of the indoor spaces plays a key role in our projects. As we were designing AON's European headquarters in the centre of Prague, we paid particular attention to ergonomics, lighting and especially acoustics. We found a partner for our vision of the space in the context of historical architecture in the people at SilentLab. They were the only ones not afraid to look for new ways and take current technical possibilities as far as they can go. The result is an extraordinary completed project that has drawn international recognition.

As part of the project we developed our own concept of small solitary meeting spaces with extremely high-quality acoustics.

DESIGNERS



Do you have an eye for design and refuse to settle for less than top quality? Our line of MICROOFFICE compatible accessories has been carefully designed for the discerning client. You can choose from a wide variety of furniture and leading-edge technologies to take your work environment to the next level.

OPTIONAL EQUIPMENT

AV TECHNOLOGY

AV connection points are built into MICROOFFICE from the factory and combine with complete soundproofing, modern equipment, and high quality audio and video to provide the best meeting environment, all while maintaining a clean and unique design in the market.

All you have to do is choose from our two options for the screen location in the MICROOFFICE: placement of AV connection points in the glass wall or in the wall panel on the right side. It's that easy!

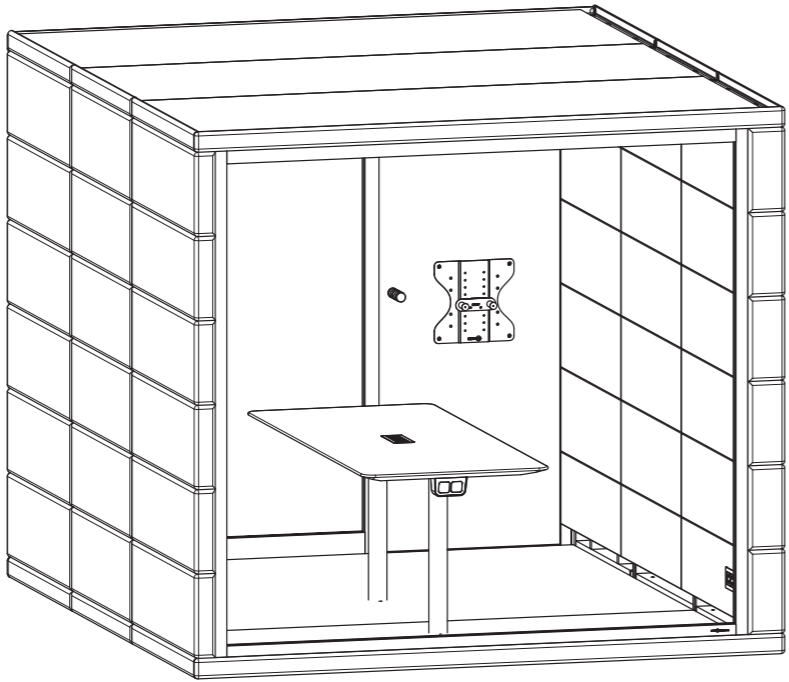
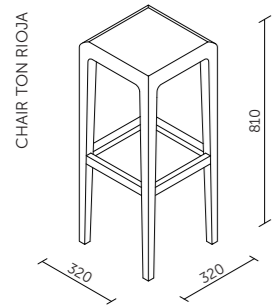

*illustration of the possible layout configuration



FURNITURE

MICROOFFICE UNIQ/PRIME/SPARK



MICROOFFICE CUBIQ

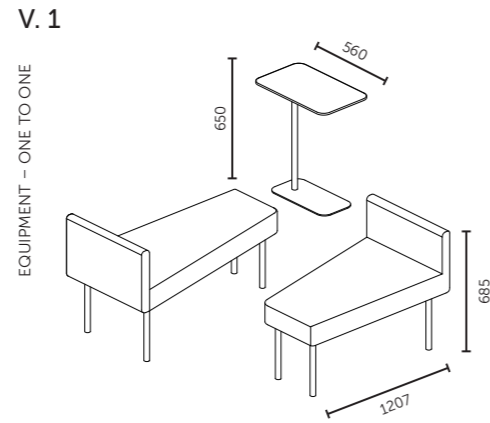

MICROOFFICE CUBIQ

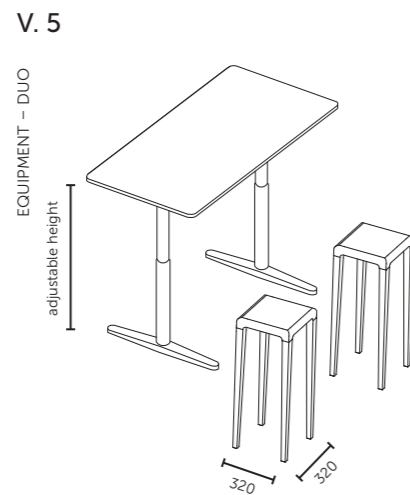
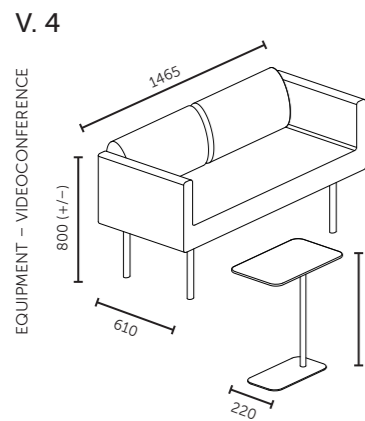
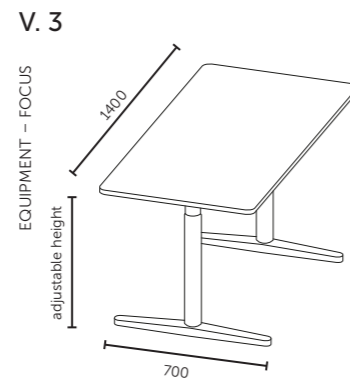
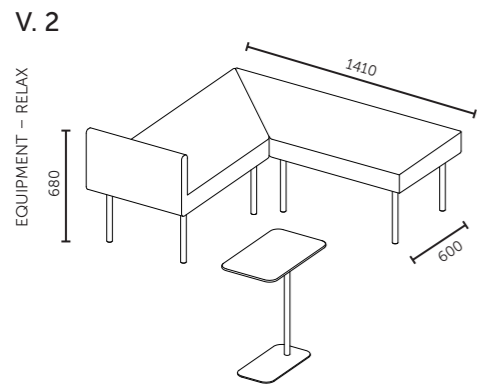

MICROOFFICE QUADRIO I

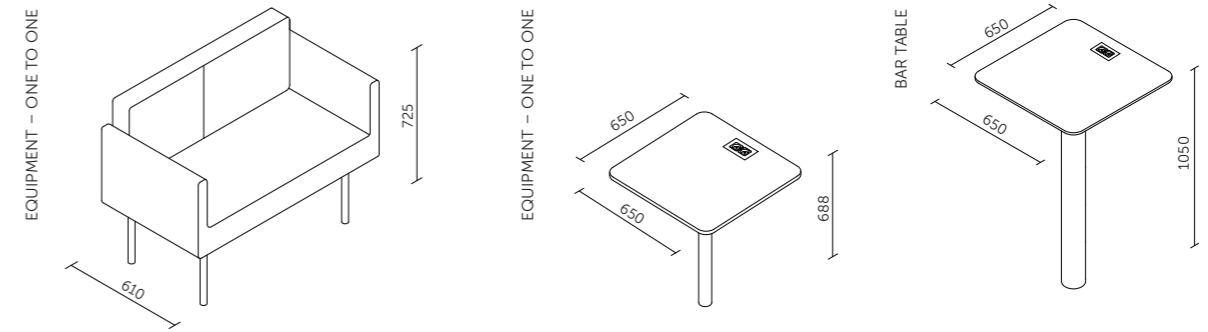

MICROOFFICE QUADRIO II, ELITE

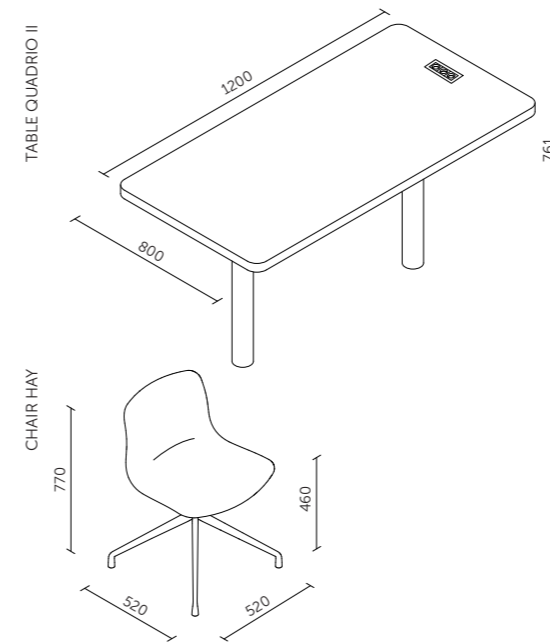

MICROOFFICE QUADRIO III/IV

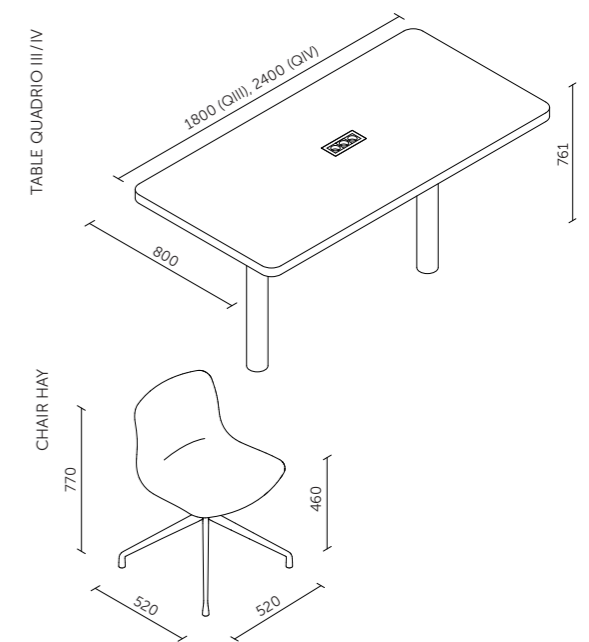

MICROOFFICE UNIQ/PRIME/CUBIQ/QUADRIO I, II, III, IV, ELITE

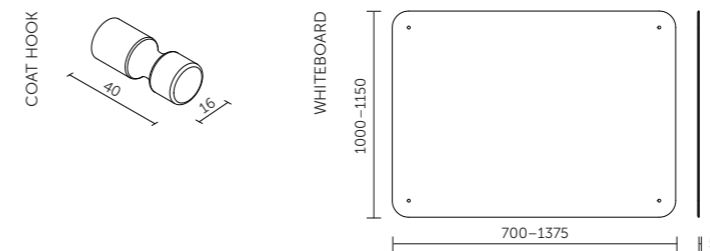

* Detailed information on individual products is available in the technical data sheets.
All furniture dimensions are given in millimeters. Illustration of a possible solution.

* Detailed information on individual products is available in the technical data sheets.
All furniture dimensions are given in millimeters. Illustration of a possible solution.

CURTAINS

TECHNICAL DETAILS FOR PLACEMENT IN MICROOFFICE

dimensions	
QII/QIII/QIV	2100 x 4490 mm / 82.7 x 176.7 in
CUBIQ	2100 x 3000 mm / 82.7 x 118.1 in
anchoring method	metal rail with carriage
fullness ratio	1:2

TECHNICAL DETAILS OF CURTAINS

materials	72% polyester, 28% cotton (festival) 69% polyester, 31% linen (estoril)
weight	199g/m ² (festival) 110g/m ² (estoril)
width	300 cm / 118 in

The rail for the hanging and curtain guide is located 60 mm from the edge of the frame.
The exact composition of the fabrics and information about the curtains and drapes can be found in the material lines.

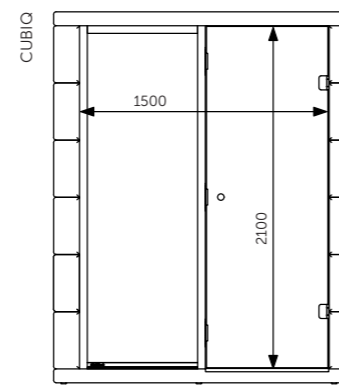
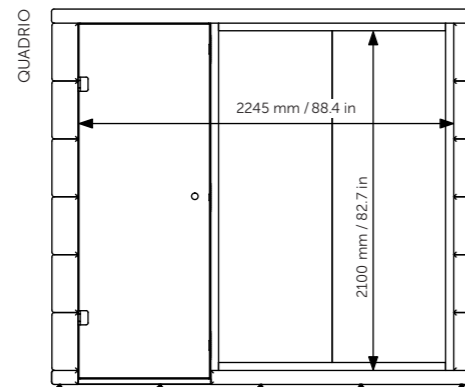
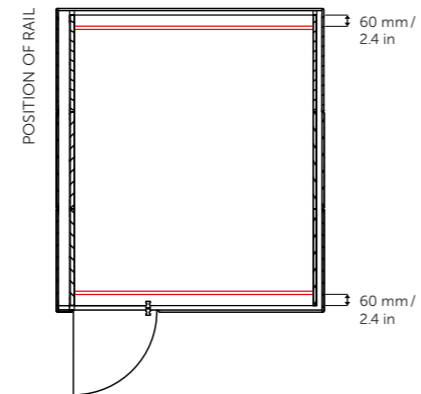

CLARITY PROTECT

Safe and sound. That's exactly how we want you to feel in our MICROOFFICE during these insecure days. To guarantee you both, we are introducing our Clarity System – an innovative way of indoor protection.

TECHNICAL DETAILS

location	inside the MICROOFFICE ventilation bowels
ozone concentration inside MICROOFFICE	< 0,01ppm*
ion production	10 000–200 000 positive and negative ions per cm ²
certification	RoHS, EMC, CE a UL

* The standard of international standards for ozone concentration is defined by a maximum value of 0.05ppm.

THE FUNCTIONALITY OF THE CLARITY SYSTEM

- Effectively eliminates a wide spectrum of dangerous microorganisms incl. COVID and SARS
- Neutralizes odors
- Decreases the threat of allergic reactions
- Effectively disinfects the air environment without chemical treatment
- Reduces the number of dust particles in the air

The Clarity system is fully integrated into our ventilation system.



TOUCHONE

Simple and fast installation without requiring professional knowledge. Easy reservation directly from the touch panel, computer or mobile device using Outlook, Microsoft Office 365, Microsoft Exchange Server or G Suite. The touch panel displays the current status of the room, booking calendar, and other booking options, such as cancellation, extension or termination.







After you've chosen the right soundproofing tech for your office, bring it to life in one of three distinctive material options. Take your first steps towards a more tranquil workspace with SOFT, focused on maximizing functionality and value. Next, there's AMBIENT, which features two fabric options for increased comfort and performance. Finally, the PULSE line offers high-end fabrics to achieve the utmost in quality and design.

SOFT

SOFT is our entry-level category, made from BOMBAY fabric for an emphasis on effortless functionality. The PVC exterior is water-repellent and sleek, sure to complement any professional workspace, while metal frames ensure long-lasting quality.

AMBIENT

Our AMBIENT line comprises two appealing fabric choices: the irresistibly soft ASPECT, made from 75% flame-retardant Trevira CS, or the durable WOOLLAND, with its natural wool fibers, water-repellent and flame-retardant finish. Either way, you'll enjoy superior comfort and functionality.

PULSE

PULSE blends high-end fabrics from natural materials. Our enticing BLAZER and SYNERGY fabrics are exclusively sourced from verified partners who place a high premium on quality. As stimulating to the eye as they are to the touch, PULSE designs feature vibrant quilted arrangements with warm colors that promote creativity and enthusiasm. WOOLLAND QUILT is the brand new addition to our PULSE fabric line, which brings a modern twist to this material due to the aesthetical quilting.

BOMBAY

SOFT

ASPECT

AMBIENT

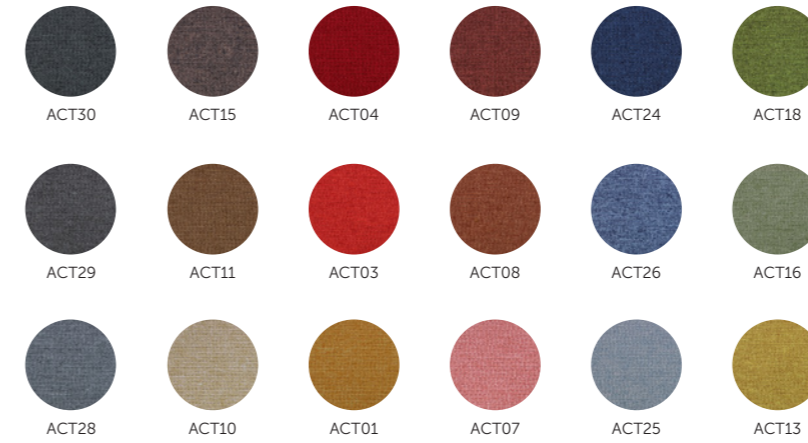

TECHNICAL DETAILS

materials 100% polyester
weight 350 g/m²
width 140 cm
abrasion resistance > 100 000

TECHNICAL DETAILS

materials 75% Trevira CS, 25% polyester
weight 325 g/m²
width 140 cm
abrasion resistance > 50 000

WOOLLAND

AMBIENT

BLAZER

PULSE

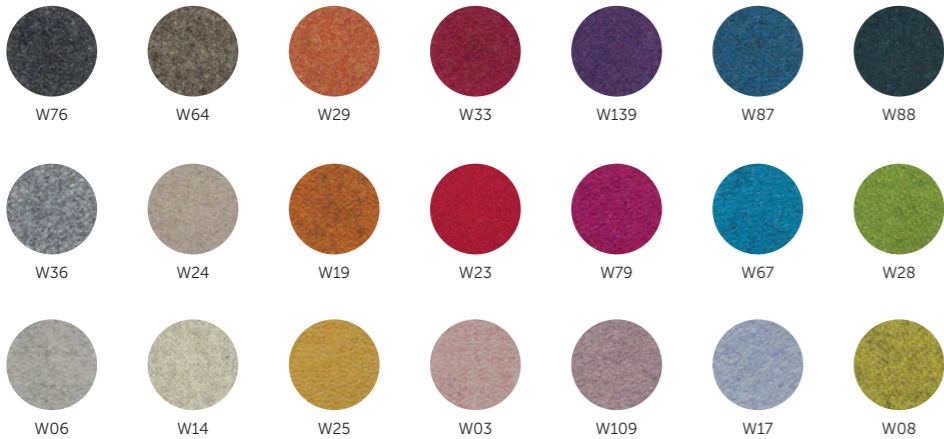

TECHNICAL DETAILS
 materials 70% wool, 30% polyamide
 weight 400 g/m²
 width 140 cm
 abrasion resistance > 100 000

TECHNICAL DETAILS
 materials 100% virgin wool
 weight 460 g/m²
 width 140 cm
 abrasion resistance > 50 000

SYNERGY

PULSE

At the customer's request, the product can also be upholstered with KVADRAT fabrics.

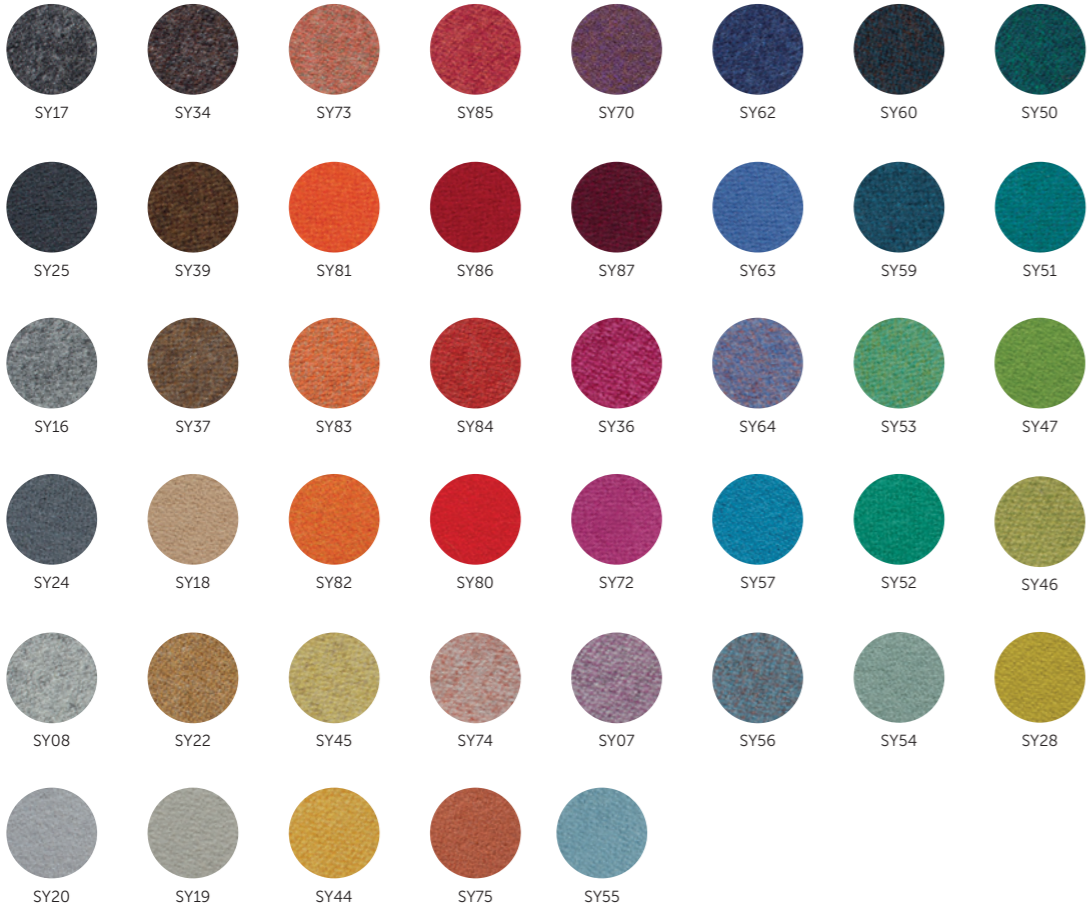

TECHNICAL DETAILS
 materials 95% virgin wool, 5% polyamide
 weight 400 g/m²
 width 140 cm
 abrasion resistance > 100 000

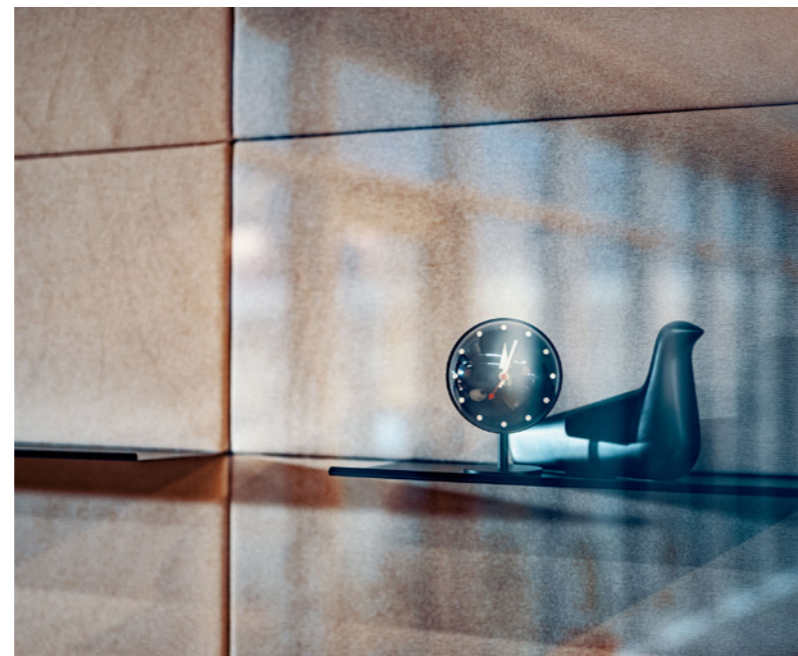

MICROOFFICE EQUIPMENT

	UNIQ	PRIME	SPARK	CUBIQ	Q I	Q II	Q III	Q IV	REALM	ELITE
PERSONS (max.)	1	1	1	4	4	5	7	9	5	5
ELECTRIC SOCKET (included in the price)	1x	1x	0	2x	2x	3x	3x	3x	3x	3x
MOTION SENSOR	●	●	●	●	●	●	●	●	●	●
AUTOMATIC TEMPERATURE REGULATION	●	●	●	●	●	●	●	●	●	●
LAMP / LED	●	●	●	●	●	●	●	●	●	x
VENTILATION	●	●	●	●	●	●	●	●	●	●
USB (table / wall)	1x	0	0	0	0	0	0	0	0	0
LAN CONNECTION (table / wall)	0	0	0	0	0	0	0	0	0	0
OAK TABLE	●	●	●	0	0	0	0	0	●	●
SEAT	0	0	0	0	0	0	0	0	●	0
COAT HOOK *	0	0	0	0	0	0	0	0	3x	0
INLET CABLE FROM THE TOP	0	0	0	0	0	0	0	0	0	0
CONTROL PANEL FOR LIGHTING AND AIR VENTILATION	0	0	0	●	●	●	●	●	●	x
BLACK DESIGN (black frame, handle, table)	0	0	0	0	0	0	0	0	0	0
GLASS CEILING	●	x	x	x	x	x	0	0	●	x
AV CONNECTION POINTS (TV screen holder + additional electric socket)	0	0	0	0	0	0	0	0	0	0
CLARITY PROTECT	0	0	0	0	0	0	0	0	0	0
WRITABLE WHITEBOARD	0	0	x	0	0	0	0	0	0	0
WRITABLE WHITEBOARD INSIDE	x	x	x	0	0	0	0	0	0	0
TWO FABRIC COLOURS	0	0	0	0	0	0	0	0	0	0
SATIN GLASS BACK WALL STICKER	0	0	0	0	0	0	0	0	0	0
SPRINKLER CONNECTION POINT (1 pcs)	0	0	0	0	0	0	0	0	0	0
COURTAINS	x	x	x	0	0	0	0	0	0	0
SHELF	x	x	x	0	0	0	0	0	2x	0
ROOM RESERVATION PANEL (connection point / installation)	0	0	0	0	0	0	0	0	0	0
WIRETAPPING ULTRASOUND JAMMER	x	x	x	x	x	x	x	x	x	0
AIR-CONDITIONING	x	x	x	x	x	x	x	x	x	0
PROCOGNITIVE LIGHT	x	x	x	0	0	0	0	0	0	●
GRAPHIC CONTROL PANEL FOR LIGHTING AND AIR VENTILATION	x	x	x	x	x	x	x	x	x	●
USB-C (power delivery)	x	x	●	x	x	x	x	x	x	x

- included in the price
- additional fee
- x not available

* MO PRIME and UNIQ 1 pcs, MO CUBIQ and other 2 pcs



CONTACT INFORMATION

+420 733 739 065
info@silent-lab.com
www.silent-lab.com
www.microoffice.eu

COMPANY ADDRESS

SilentLab s.r.o.
Za Zastavkou 373
111 01 Prague – Czech Republic

The final product configuration may differ
from the versions shown in the photographs.

All MICROOFFICE products are patent pending.
SilentLab® and MICROOFFICE® are registered trademark.

All intellectual property rights („Rights“), whether registered or not, relating to any content, texts, photographs, images, logos, instructions, designs, technical solutions, etc. (“Content“) are the property of SilentLab s.r.o. (“Owner“) and any interference with these Rights to any Content or part thereof without the prior express and written consent of the Owner is not permitted.

Any use of the Content not expressly authorized in writing in advance, with the exception of internal and non-commercial use of the unmodified Content for the purposes of the customer's own order, is considered an infringement of the Owner's Rights. In particular (not exclusively), any reproduction, change, addition, merger or other modification of the Content is prohibited without the prior express written consent of the Owner.

FEEL WELL WORK WELL